

Enforcer® Bed Buddy Trailer Tilt Installation Instructions

READ ALL INSTRUCTIONS CAREFULLY PRIOR TO INSTALLATION

HARDWARE INCLUDED:

Qty.	Description
6	#12 x 3/4" Self-Tapping Screws
1	Frame Bracket with "Inner" Ball Stud (Bracket 1)
1	Frame Bracket with "Outer" Ball Stud (Bracket 2)
1	High Pressure Gas Spring

TOOLS REQUIRED:

Power Drill
5/32" Drill Bit (optional)
3/6" Socket Wrench
Tape Measure
Marker
Tape or Clamping Device

IMPORTANT NOTE: Trailer Bed Buddy is a high pressure gas spring that **cannot be compressed by hand**. The Trailer Bed Buddy's default position is an extended length of 20.0 inches and has a compressed length of 12.0 inches. Failure to mount brackets in the proper locations as described below may cause damage to the trailer lift or its hardware and will void warranty!

1. With the trailer unloaded and **unhooked from the vehicle**, place the tongue on the ground and brace the trailer deck in the tilt "up" position. As an added precaution, have another person assist to insure that the trailer deck cannot fall from tilt "up" position. **WARNING: Personal injury may occur if trailer should fall from tilt "up" position. Take appropriate precautions to protect yourself.**
2. From the trailer deck pivot bolt, measure 25.0 inches towards the front of the trailer. Mark this on the underside of the trailer bed, as shown in illustration at **Location A**. **NOTE: This measurement will be used only as a starting point. Bracket 1 will most likely not be mounted exactly 25 inches from the deck pivot.**
3. Temporarily tape or clamp **Bracket 1** in position by centering on your mark from step 2.
4. With **Bracket 1** in place, let the trailer deck down and lock into travel mode. The trailer tongue should still be on the ground at this point.
5. Measure 12.25 inches from **Bracket 1** toward the tongue and temporarily tape or clamp **Bracket 2** on tongue frame so that there is 12.25 inches between the ball stud of **Bracket 1** and the ball stud of **Bracket 2**, as shown in illustration at **Location B**.
6. With the tongue of the trailer still on the ground, tilt the trailer deck all the way up so the rear of the deck touches the ground, and measure the distance between the ball studs of **Bracket 1 & 2**.
7. If distance is 19.5 to 20.0 inches, go on to step 8.

If the distance is MORE than 20.0 inches: Move BOTH brackets an EQUAL distance towards the pivot point until the distance is 19.75 inches.

If the distance is LESS than 19.5 inches: Move BOTH brackets an EQUAL distance away from the pivot point until the distance is 19.75 inches.

NOTE: The purpose of moving both brackets an EQUAL distance is to maintain the 12.25 dimension while adjusting to get the 19.75 dimension.

8. Tilt the trailer deck back to the travel position and re-measure the brackets to ensure that they are still at least 12.25 inches apart.
9. Using the 3/8" socket with the power drill, mount the brackets permanently into position using the self-drilling screws provided. The 5/32" drill bit may have to be used to drill a pilot hole. **IMPORTANT: Both brackets MUST be mounted to metal. DO NOT mount the brackets to the wood deck as the screws provided with this kit will not stay attached to wood and the wood will become weak over time.**
10. Remove the small retainer clips which wrap around the neck at each end of the gas spring. These must be removed before the trailer lift can be installed onto the brackets. Take note of how they were removed as they must be reinstalled after the Trailer Bed Buddy.
11. Attach the body/barrel end of the gas spring to **Bracket 1**. **IMPORTANT: (The barrel end of the spring must be in the top position with the shaft end pointed in the down position as indicated in the illustration.) This will ensure that the piston of the gas spring stays lubricated by the oil inside the spring.**
12. Tilt the trailer deck until you are able to lock the other end of the gas spring into place on Bracket 2. **HELPFUL HINT: (If you are unable to tilt the trailer far enough to attach the other end of the gas spring to Bracket 2, slightly raise the trailer tires, allowing the trailer frame to open wider.) This can best be accomplished by moving the trailer to a location in your yard or driveway that has a high spot (crown).**

COMMON QUESTIONS:

1. **Why is the trailer not hooked up to my vehicle during installation?** By making all measurements with the trailer tongue on the ground, you will eliminate any chance that the deck would open farther than what the Trailer Bed Buddy will allow, which either damages the bracket or the gas spring. Example: Backing your trailer up to a ditch and trying to tilt your deck far enough to touch the ground.
2. **My trailer is not balanced and is very heavy in front. Will the Trailer Bed Buddy have enough force to keep my trailer tilted up?** If you have something mounted to the front of your trailer like a metal salt shield and it takes two hands or even two people to tilt your deck up, you may need to use two Trailer Bed Buddys.
3. **My trailer has a fiber glass (or aluminum) cover. Will the Trailer Bed Buddy have enough force to keep my trailer tilted up?** As long as your trailer deck is balanced, you should only need one Trailer Bed Buddy. A common problem that the Trailer Bed Buddy solves is that a trailer deck can stay tilted in the "up" position on its own, even when the cover is opened.

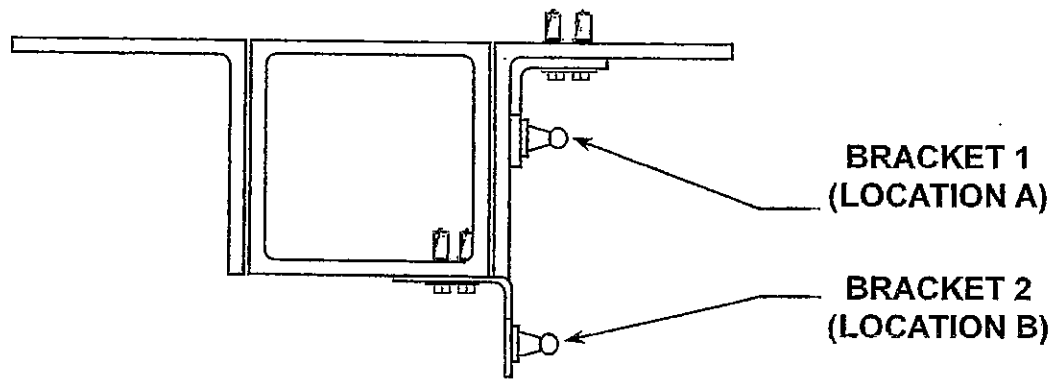
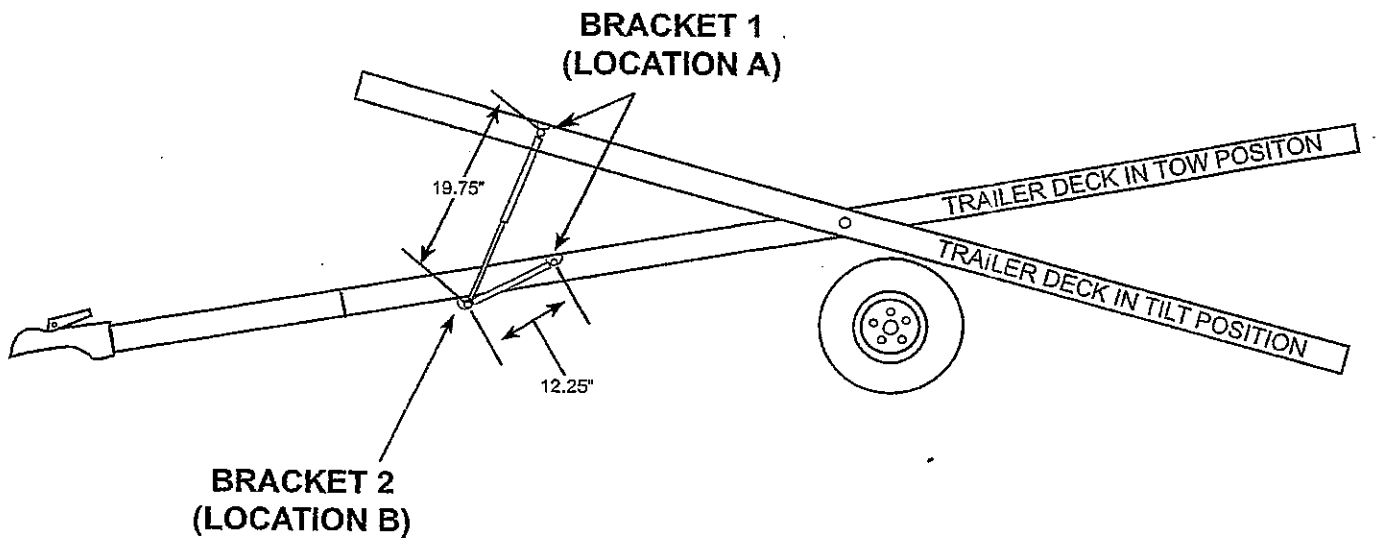

CLOSE-UP VIEW IN TOW POSITION
(FRONT CUT-AWAY ANGLE)

